

NEW! *Dynamic Cable Manager***specifications**

The dynamic cable manager shall reduce the strain that static mounts experience during the opening and closing of electrical cabinet doors. The cable bundle shall remain stationary with a ball-and-socket tether transferring and absorbing the strain during assembly, installation, and transportation. The mounts shall be manufactured from a Nylon 6.6 material with a rubber adhesive.

**Dynamic Cable Manager**

1.12" x 1.12"
(28.4mm x 28.4mm)
mounting base: ABDCM30-A-C

Recommended Cable Ties

Use with PAN-TY® or DOME-TOP®
Barb Ty cable ties up to Standard
cross section (50 lbs. minimum
loop tensile strength)

technical information

Patent:	Pending
Mount material:	Nylon 6.6
Color:	White
Adhesive type:	Rubber
Adhesive application temperature range:	-40°F to 120°F (-40°C to 49°C); continuous
Environmental compliance:	2002/95/EC RoHS

key features and benefits

Unique mount design	Transfers the dynamic load of the bundle away from the edge of the mount; preventing mount from peeling off panel surface
Ball-and-socket tether	Retains position of bundle relative to hinge while opening and closing panel door(s), reduces normal load by up to 70% with bundles over three-quarters of an inch, and reduces peak shear loads by up to 75% compared to typical static mounts; eliminating the risk for potential shocks and shorts that could damage internal components and extending service life of cable bundles and mounts
Universal slot design	Permits use of any cable tie with a 50 lbs. minimum loop tensile strength; providing design flexibility
Rubber adhesive	Rated for service conditions -40°F to 120°F (-40°C to 49°C); suitable for use within the control panel environment

applications

The *PANDUIT* dynamic cable manager is a reliable and cost-effective solution for securing cable bundles in control panels that have hinged access into the panel box, which also ensures continuity of the related systems in the physical infrastructure. These mounts are well suited for use with control panels

featuring control lights, touch pads, and switches in the panel door. The unique mount allows the panel door to be easily opened and closed and extends the service life of the adhesive in applications where bundle movement is unavoidable.

ordering information

Part Number	Used With Cable Ties	Mounting Method	Length (A)		Width (B)		Overall Width (C)		Height (D)		Material	Color	Std. Pkg. Qty.	Std. Ctn. Qty.
			In.	mm	In.	mm	In.	mm	In.	mm				
ABDCM30-A-C	Miniature, Intermediate, Standard	Rubber Adhesive	1.12	28.4	1.12	28.4	1.98	50.3	.66	16.8	Nylon 6.6	White	100	1000

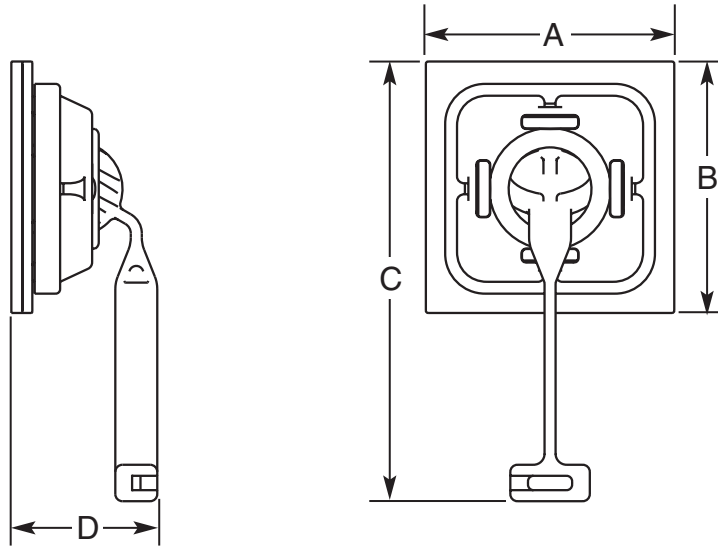

typical installation

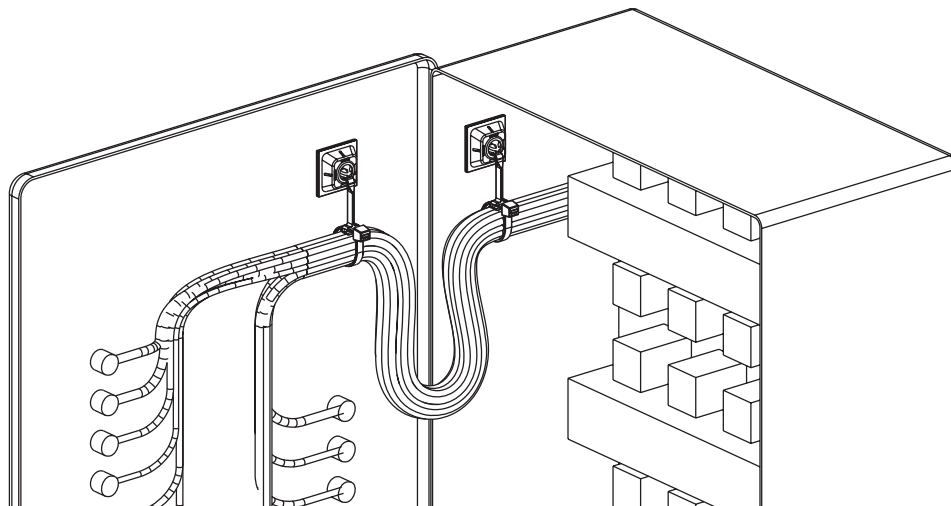

WORLDWIDE SUBSIDIARIES AND SALES OFFICES

PANDUIT CANADA
Markham, Ontario
cs-cdn@panduit.com
Phone: 800.777.3300

PANDUIT EUROPE LTD.
London, UK
cs-emea@panduit.com
Phone: 44.20.8601.7200

PANDUIT SINGAPORE PTE. LTD.
Republic of Singapore
cs-ap@panduit.com
Phone: 65.6305.7575

PANDUIT JAPAN
Tokyo, Japan
cs-japan@panduit.com
Phone: 81.3.3767.7011

PANDUIT LATIN AMERICA
Jalisco, Mexico
cs-la@panduit.com
Phone: 52.333.777.6000

PANDUIT AUSTRALIA PTY. LTD.
Victoria, Australia
cs-aus@panduit.com
Phone: 61.3.9794.9020

For a copy of *PANDUIT* product warranties, log on to www.panduit.com/warranty



For more information

Visit us at www.panduit.com

Contact Customer Service by email: cs@panduit.com
or by phone: 800-777-3300 and reference WASP11

©2008 *PANDUIT* Corp.
ALL RIGHTS RESERVED.

WW-WASP11

10/2008